

LAWN CARE CATALOG



SPECIALISTS IN LIQUID
HANDLING PRODUCTS
EST. 1983

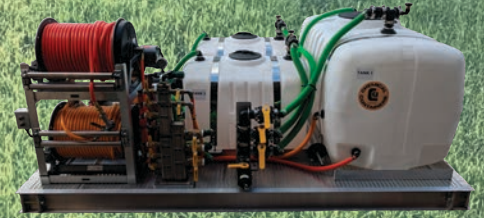
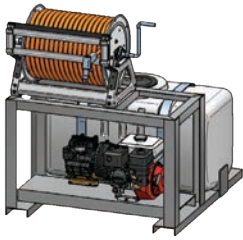
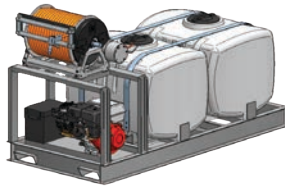

TABLE OF CONTENTS

50 GALLON SKID	PAGE 1
100 GALLON SKID	PAGE 2
200 GALLON SKID	PAGE 3
200 GALLON CURBSIDE SKID	PAGE 4
300 GALLON SKID	PAGE 5
100/100 GALLON DUAL TANK SKID	PAGE 6
200/100 GALLON DUAL TANK SKID	PAGE 7
400/300 GAL DUAL TANK SKID	PAGE 8
200/30/30 GALLON MULTI TANK SKID	PAGE 9
300/100/100 GALLON MULTI TANK SKID	PAGE 10
300/200/100 GALLON MULTI TANK SKID	PAGE 11
LAWNCARE TRUCK	PAGE 12
ENCLOSED LAWNCARE TRUCK	PAGE 13
PUMPS, ENGINES, & METERS	PAGE 14
TANKS	PAGE 15
COMPLETE UNITS & KITS	PAGE 16
PARTS	PAGE 17
VORTEX GRANULAR SPREADERS	PAGE 18
ATV BOOMS AND SPRAY SYSTEM PARTS	PAGE 19
CUSTOM EQUIPMENT	PAGE 20



50 GALLON SKID



100 GALLON SKID

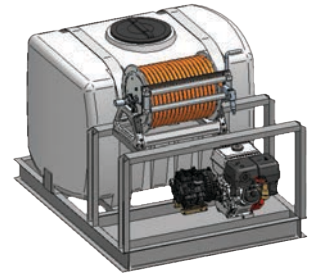

200 GALLON SKID

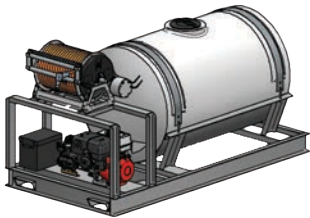

300 GALLON SKID

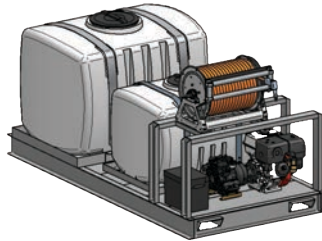

200/100 GALLON SKID

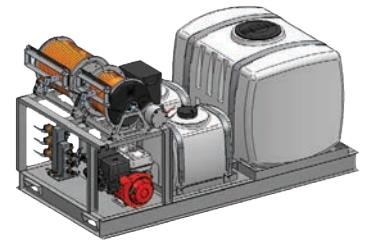

200/30/30 GALLON SKID

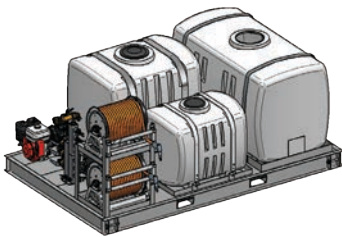

300/200/100 GALLON SKID

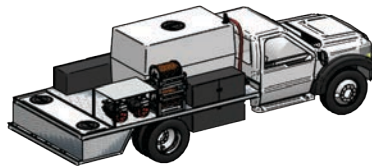

LAWN CARE TRUCK



ENCLOSED LAWN CARE TRUCK



50 GALLON SKID

50 Gallon Poly - Skid Layout

- (1) 50 Gallon Poly PCO Tank
- (1) 150' of 1/2" Spray Hose, w/ Quick Coupler
- (1) Manual Hose Reel, w/ Roller Guides
- (1) Choice of Pump
- (1) 5.5 HP Honda Engine, Manual Start
- (1) JD9 Trigger Spray Gun, w/ Quick coupler

- 3/4" Tank Mounted Air Gap Fill
- Roller Guides on Hannay Hose Reel
- Adjustable High Pressure Jet Agitation
- Remote Mounted Suction Strainer-Filter
- Chemical Resistant Polyethylene Tanks 5 Year UV Rated
- Corrosion Resistant T6061 Aluminum Frame
- All Fittings Poly, Brass or Stainless Steel
- Factory Tested w/ OEM Parts Registration
- Long Life, Fuel-Efficient Honda Engines
- Air Gap Fillers Included

Pump Options

Udor Kappa43 (10 GPM, 560 PSI)

Hypro D30 (9.6 GPM, 580 PSI)

Optional Upgrades

- 300' Capacity Electric Hose Reel
- Electric Start Engine
- Battery, Battery Box, and Wiring

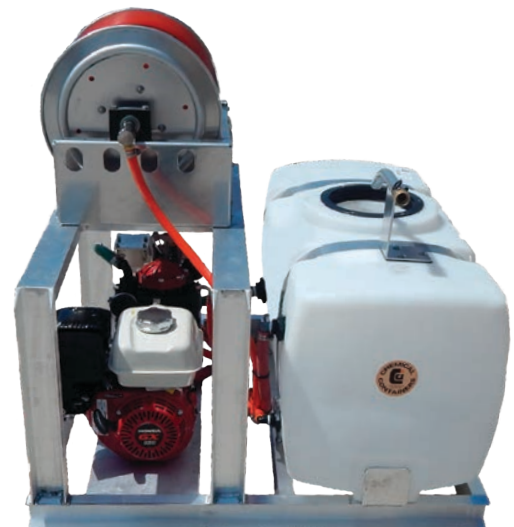
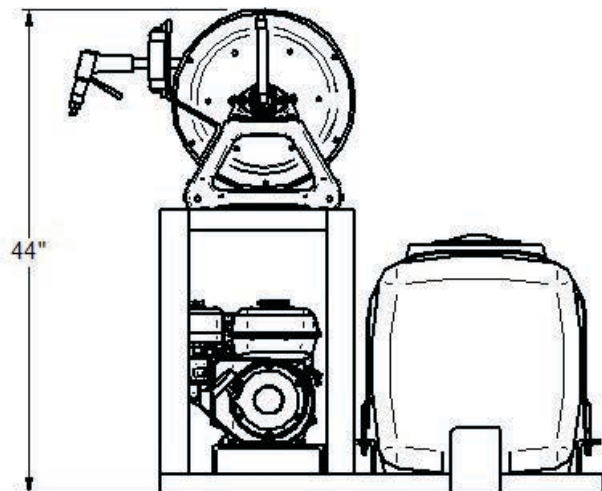
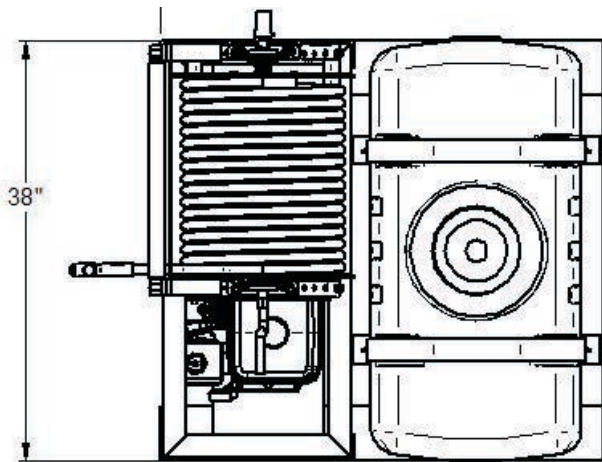
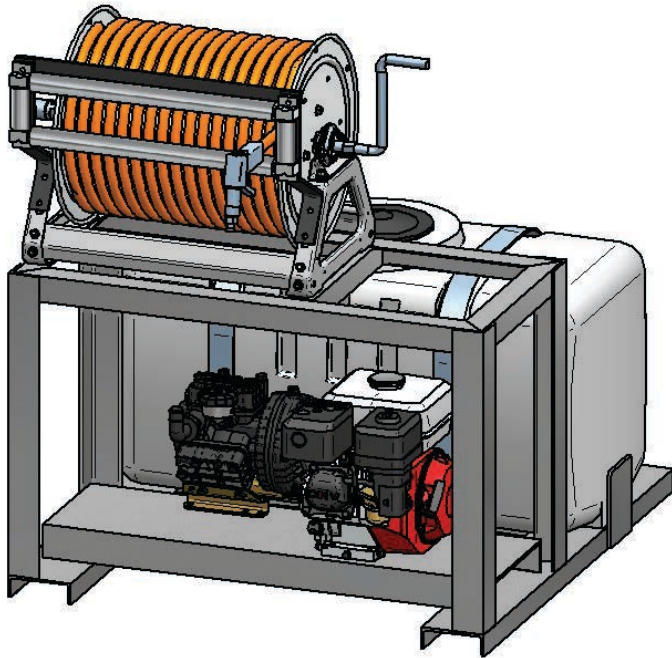



100 GALLON SKID

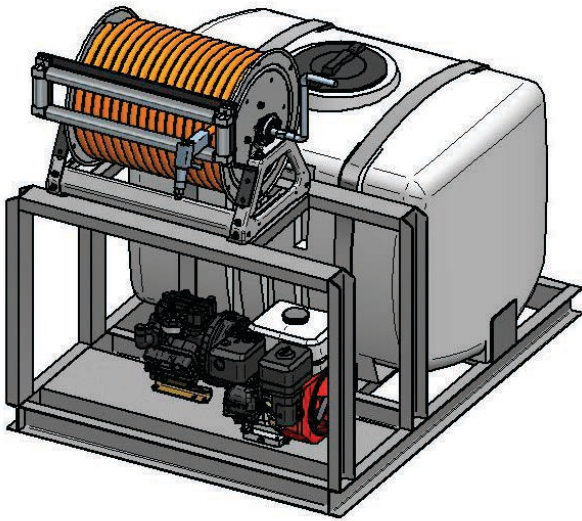

100 Gallon Poly - Skid Layout

- (1) 100 Gallon Poly PCO Tank
- (1) 150' of 1/2" Spray Hose, w/ Quick Coupler
- (1) Manual Hose Reel, w/ Roller Guides
- (1) Choice of Pump
- (1) 5.5 HP Honda Engine, Manual Start
- (1) JD9 Trigger Spray Gun, w/ Quick Coupler

- 3/4" Tank Mounted Air Gap Fill
- Roller Guides on Hannay Hose Reel
- Adjustable High Pressure Jet Agitation
- Remote Mounted Suction Strainer- Filter
- Chemical Resistant Polyethylene Tanks 5 Year UV Rated
- Corrosion Resistant T6061 Aluminum Frame
- All Fittings Poly, Brass or Stainless Steel
- Factory Tested w/ OEM Parts Registration
- Long Life, Fuel-Efficient Honda Engines
- Air Gap Fillers Included

Pump Options

Udor Kappa43 (10 GPM, 560 PSI)

Hypro D30 (9.6 GPM, 580 PSI)

Optional Upgrades

- 300' Capacity Electric Hose Reel
- Electric Start Engine
- Battery, Battery Box, and Wiring

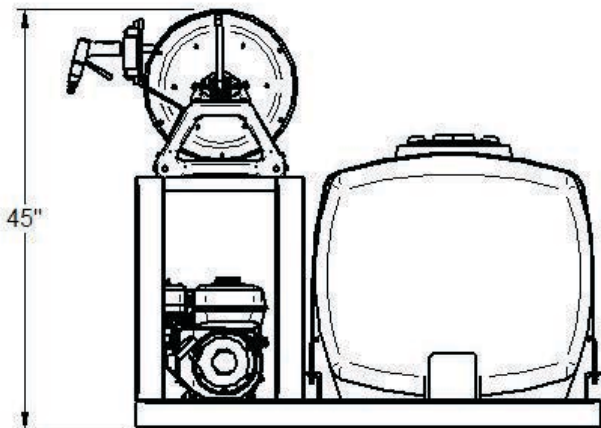
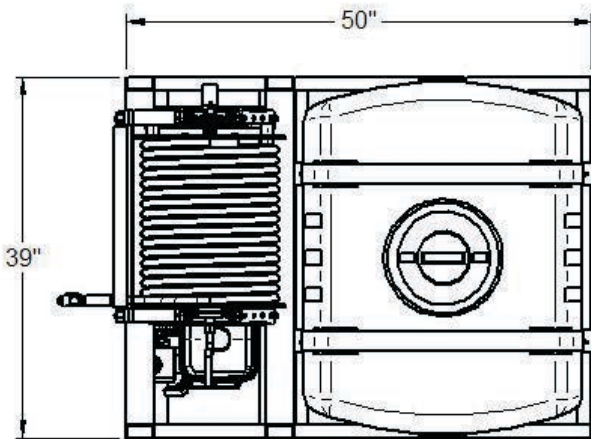



200 GALLON SKID

200 Gallon Poly - Skid Layout

- (1) 200 Gallon Poly PCO Tank
- (1) 150' of 1/2" Spray Hose, w/ Quick Coupler
- (1) Manual Hose Reel, w/ Roller Guides
- (1) Choice of Pump
- (1) 5.5 HP Honda Engine, Manual Start
- (1) JD9 Trigger Spray Gun, w/ Quick Coupler

- 3/4" Tank Mounted Air Gap Fill
- Roller Guides on Hannay Hose Reel
- Adjustable High Pressure Jet Agitation
- Remote Mounted Suction Strainer- Filter
- Chemical Resistant Polyethylene Tanks 5 Year UV Rated
- Corrosion Resistant T6061 Aluminum Frame
- All Fittings Poly, Brass or Stainless Steel
- Factory Tested w/ OEM Parts Registration
- Long Life, Fuel-Efficient Honda Engines
- Air Gap Fillers Included

Pump Options

- Udor Kappa43 (10 GPM, 560 PSI)
- Hypro D30 (9.6 GPM, 580 PSI)

Optional Upgrades

- Udor Kappa55 w/ 8 HP Honda Engine (15 GPM, 560 PSI)
- Hypro D50 w/ 8 HP Honda Engine (14 GPM, 580 PSI)
- 300' Capacity Electric Hose Reel
- Electric Start Engine
- Battery, Battery Box, and Wiring

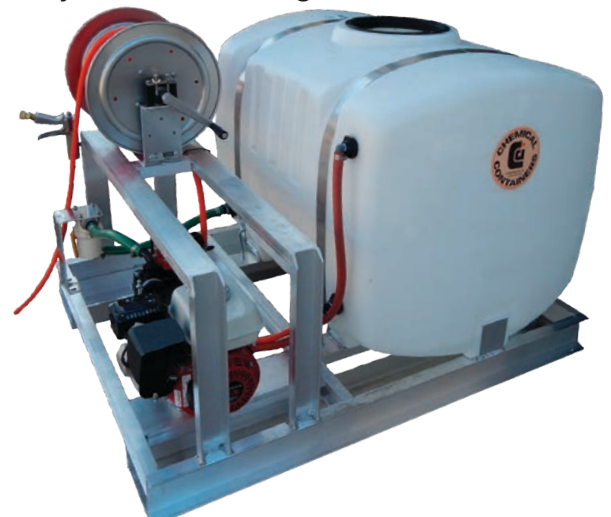
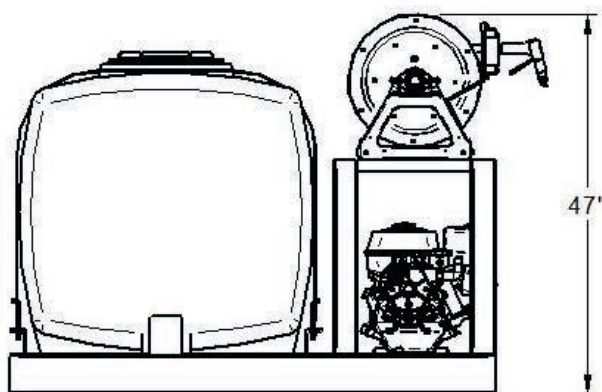
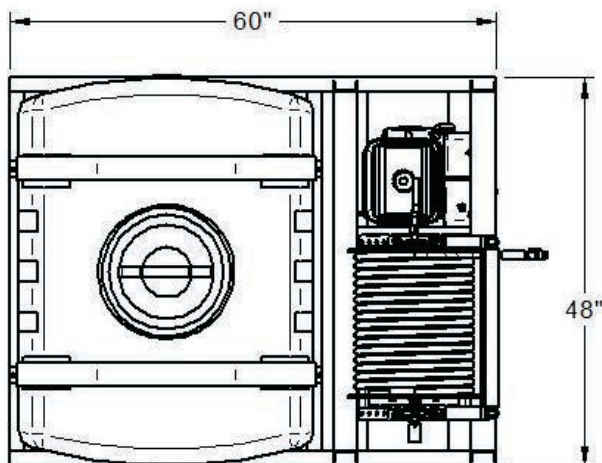
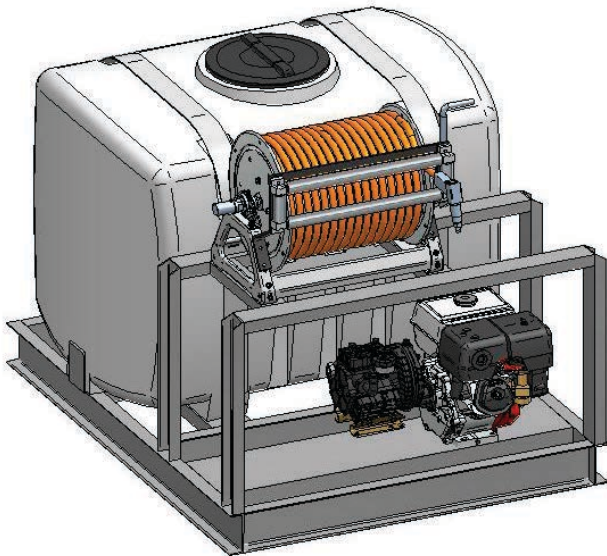



200 GALLON CURBSIDE SKID

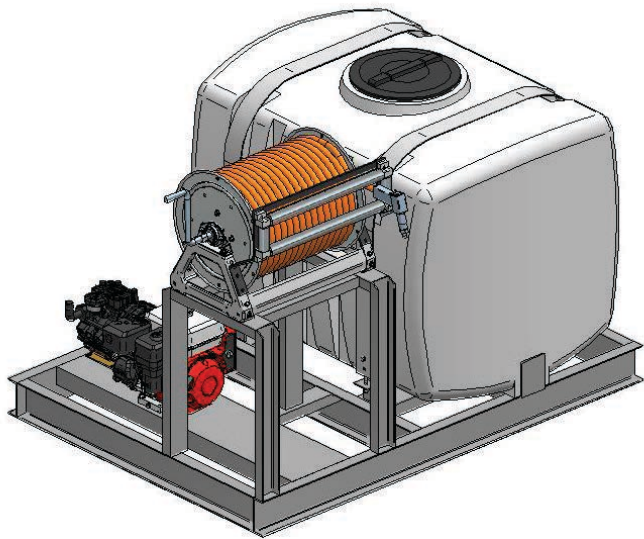

200 Gallon Poly - Skid Layout

- (1) 200 Gallon Poly PCO Tank
- (1) 150' of 1/2" Spray Hose, w/ Quick Coupler
- (1) Manual Hose Reel, w/ Roller Guides
- (1) Choice of Pump
- (1) 5.5 HP Honda Engine, Manual Start
- (1) JD9 Trigger Spray Gun, w/ Quick Coupler

- 3/4" Tank Mounted Air Gap Fill
- Roller Guides on Hannay Hose Reel
- Adjustable High Pressure Jet Agitation
- Remote Mounted Suction Strainer- Filter
- Chemical Resistant Polyethylene Tanks 5 Year UV Rated
- Corrosion Resistant T6061 Aluminum Frame
- All Fittings Poly, Brass or Stainless Steel
- Factory Tested w/ OEM Parts Registration
- Long Life, Fuel-Efficient Honda Engines
- Air Gap Fillers Included

Pump Options

- Udor Kappa43 (10 GPM, 560 PSI)
- Hypro D30 (9.6 GPM, 580 PSI)

Optional Upgrades

- Udor Kappa55 w/ 8 HP Honda Engine (15 GPM, 560 PSI)
- Hypro D50 w/ 8 HP Honda Engine (14 GPM, 580 PSI)
- 300' Capacity Electric Hose Reel
- Electric Start Engine
- Battery, Battery Box, and Wiring

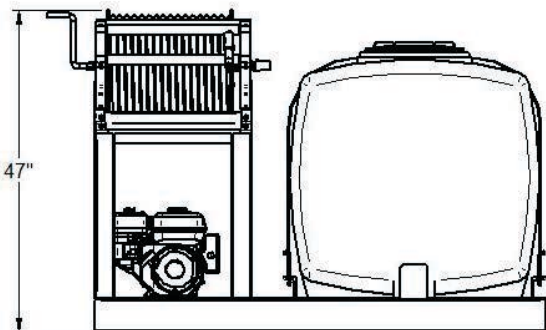
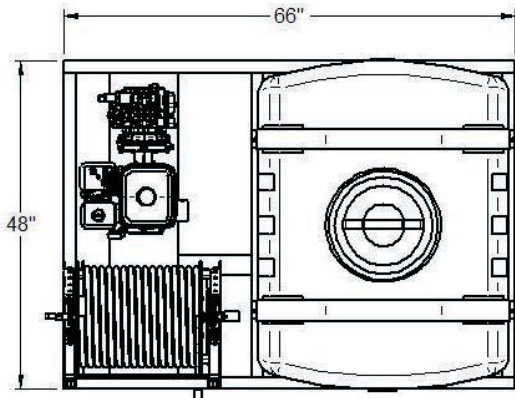



300 GALLON SKID

300 Gallon Poly - Skid Layout

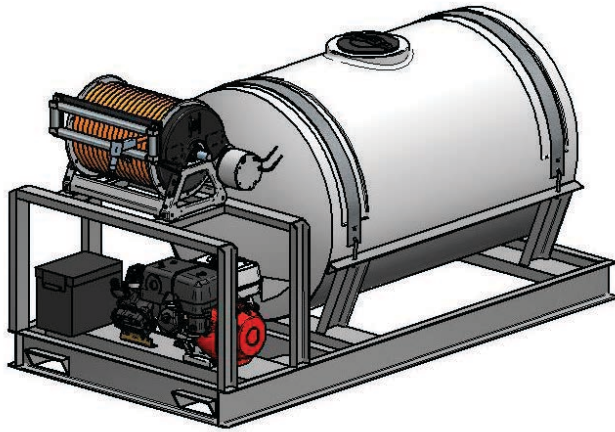

- (1) 300 Gallon Poly Applicator Tank
- (1) 300' of 1/2" Spray Hose, w/ Quick coupler
- (1) 12V Electric Hose Reel, w/ Roller Guides
- (1) Choice of Pump
- (1) 8 HP Honda Engine, Electric Start
- (1) JD9 Trigger Spray Gun, w/ Quick Coupler

- 3/4" Tank Mounted Air Gap Fill
- Roller Guides on Hannay Hose Reel
- Adjustable High Pressure Jet Agitation
- Remote Mounted Suction Strainer- Filter
- Chemical Resistant Polyethylene Tanks 5 Year UV Rated
- Corrosion Resistant T6061 Aluminum Frame
- All Fittings Poly, Brass or Stainless Steel
- Factory Tested w/ OEM Parts Registration
- Long Life, Fuel-Efficient Honda Engines
- Air Gap Fillers Included
- Battery, Battery Box, and Wiring

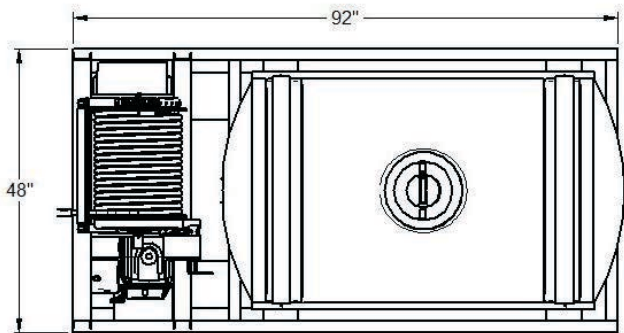

Pump Options

- Udor Kappa55 (15 GPM, 560 PSI)
- Hypro D50 (14 GPM, 580 PSI)
- Larger Pumps and Engines Available

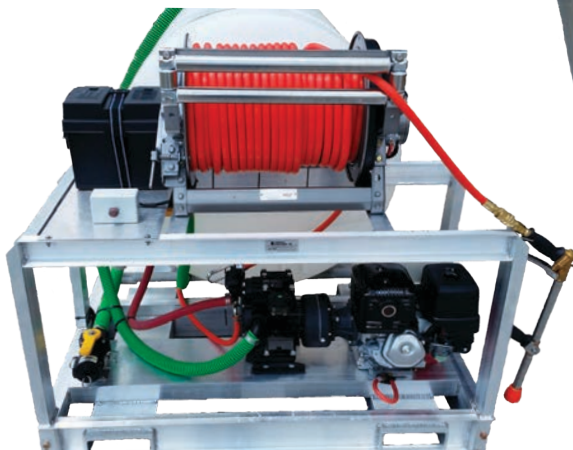
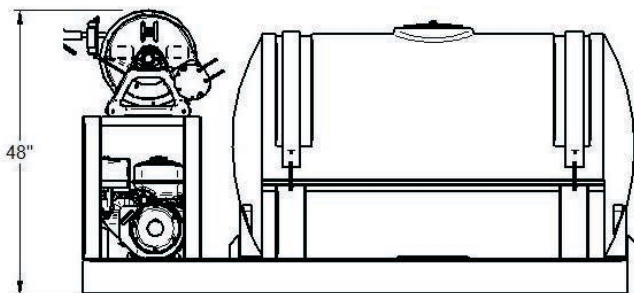



100/100 GALLON DUAL TANK SKID

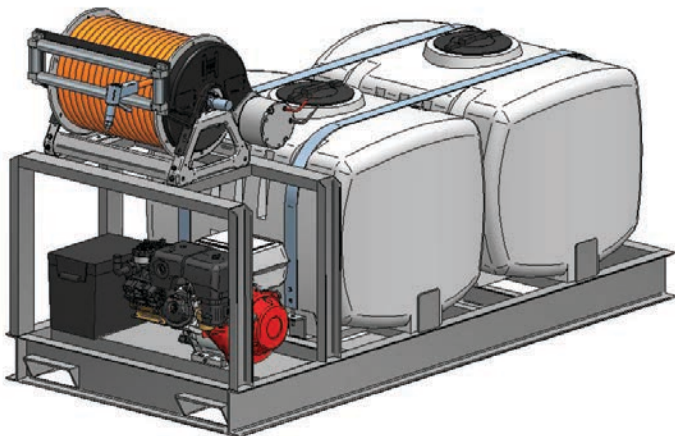

100/100 Gallon Poly - Skid Layout

- (2) 100 Gallon Poly PCO Tank
- (1) 300' of 1/2" Spray Hose, w/ Quick coupler
- (1) 12V Electric Hose Reel, w/ Roller Guides
- (1) Choice of Pump
- (1) 8 HP Honda Engine, Electric Start
- (1) JD9 Trigger Spray Gun, w/ Quick Coupler

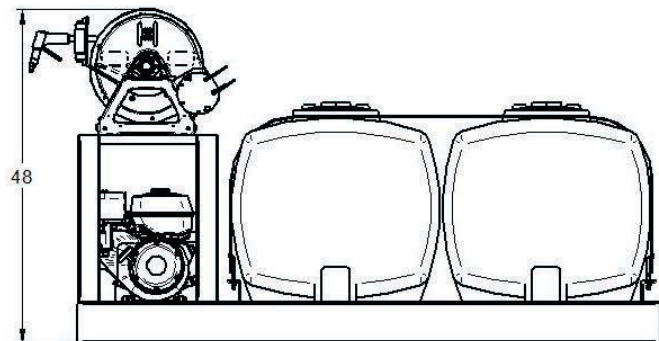
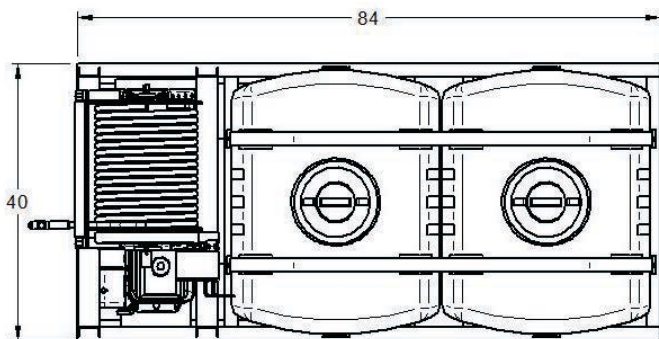

- 3/4" Tank Mounted Air Gap Fill
- Roller Guides on Hannay Hose Reel
- Adjustable High Pressure Jet Agitation
- Remote Mounted Suction Strainer- Filter
- Chemical Resistant Polyethylene Tanks 5 Year UV Rated
- Corrosion Resistant T6061 Aluminum Frame
- All Fittings Poly, Brass or Stainless Steel
- Factory Tested w/ OEM Parts Registration
- Long Life, Fuel-Efficient Honda Engines
- Air Gap Fillers Included
- Battery, Battery Box, and Wiring

Pump Options

- Udor Kappa55 (15 GPM, 560 PSI)
- Hypro D50 (14 GPM, 580 PSI)
- Larger Pumps and Engines Available

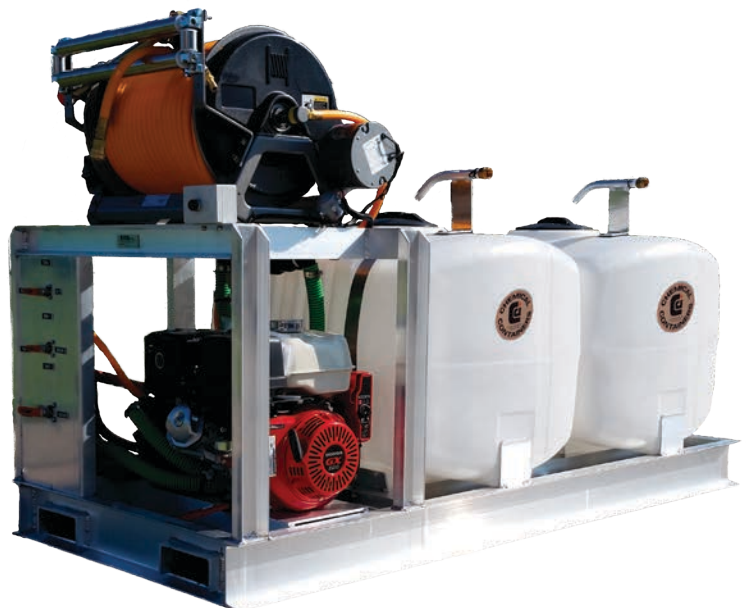



200/100 GALLON DUAL TANK SKID

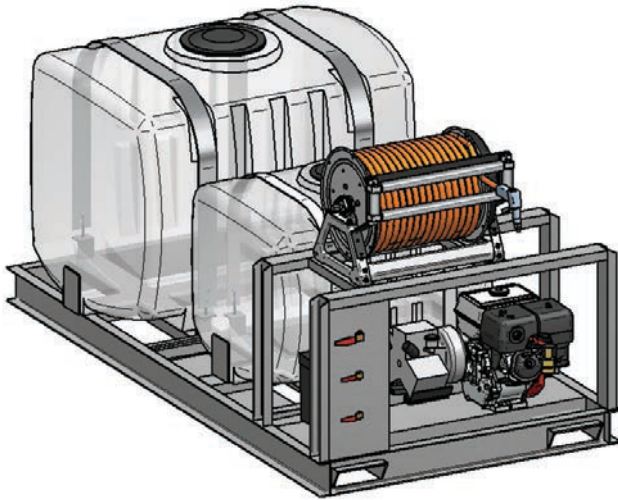

200/100 Gallon Poly - Skid Layout

- (1) 200 Gallon Poly PCO Tank
- (1) 100 Gallon Poly PCO Tank
- (1) 300' of 1/2" Spray Hose, w/ Quick coupler
- (1) 12V Electric Hose Reel, w/ Roller Guides
- (1) Choice of Pump
- (1) 8 HP Honda Engine, Electric Start
- (1) JD9 Trigger Spray Gun, w/ Quick Coupler

- 3/4" Tank Mounted Air Gap Fill
- Roller Guides on Hannay Hose Reel
- Adjustable High Pressure Jet Agitation
- Remote Mounted Suction Strainer- Filter
- Chemical Resistant Polyethylene Tanks 5 Year UV Rated
- Corrosion Resistant T6061 Aluminum Frame
- All Fittings Poly, Brass, or Stainless Steel
- Factory Tested w/ OEM Parts Registration
- Long Life, Fuel-Efficient Honda Engines
- Air Gap Fillers Included
- Battery, Battery Box and Wiring

Pump Options

- Udor Kappa55 (15 GPM, 560 PSI)
- Hypro D50 (14 GPM, 580 PSI)
- Larger Pumps and Engines Available

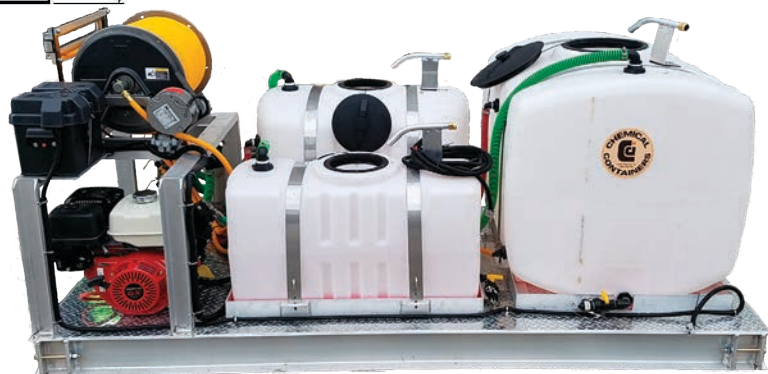
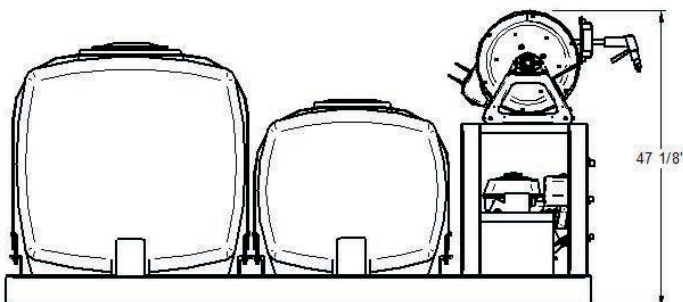
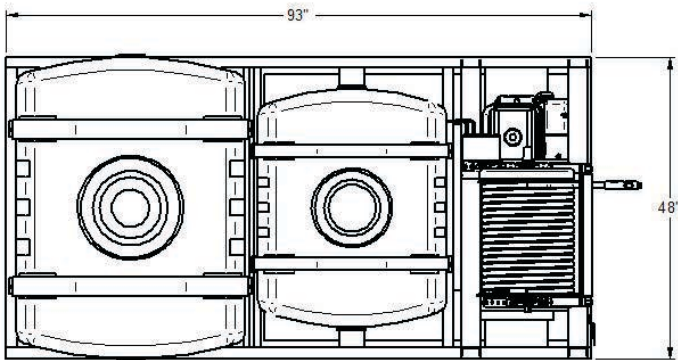



400/300 GALLON DUAL TANK SKID

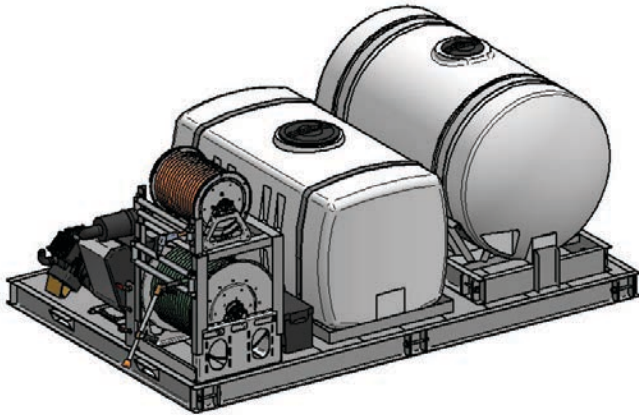

400/300 Gallon Poly - Skid Layout

- (1) 400 Gallon Poly Applicator Tank
- (1) 300 Gallon Poly PCO Tank
- (1) 6 Gallon Hand Wash Tank w/ 12 Volt Pump
- (1) 300' of 1/2" Spray Hose, w/ Quick Coupler
- (1) 300' of 3/4" Spray Hose, w/ Quick Coupler
- (2) 12V Electric Hose Reel, w/ Roller Guides
- (1) Choice of Pump
- (1) 8 HP Honda Engine, Electric Start
- (2) JD9 Trigger Spray Gun, w/ Quick Coupler

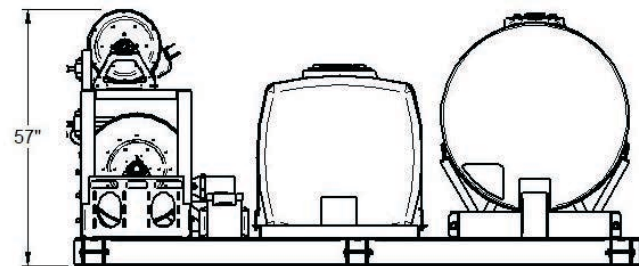
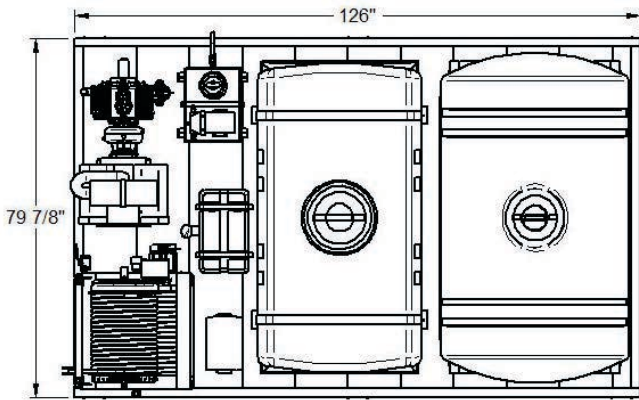

- 3/4" Tank Mounted Air Gap Fill
- Roller Guides on Hannay Hose Reel
- Adjustable High Pressure Jet Agitation
- Remote Mounted Suction Strainer- Filter
- Chemical Resistant Polyethylene Tanks 5 Year UV Rated
- Corrosion Resistant T6061 Aluminum Frame
- All Fittings Poly, Brass or Stainless Steel
- Factory Tested w/ OEM Parts Registration
- Long Life, Fuel-Efficient Honda Engines
- Air Gap Fillers Included
- Battery, Battery Box, and Wiring

Pump Options

- Udor Kappa55 (15 GPM, 560 PSI)
- Hypro D50 (14 GPM, 580 PSI)
- Larger Pumps and Engines Available

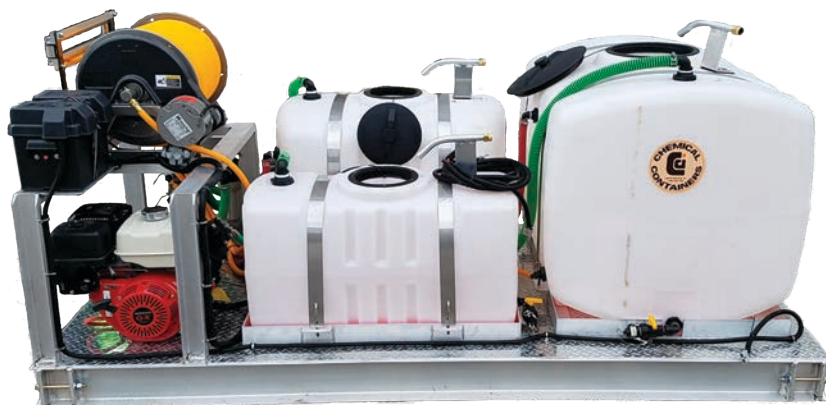



200/30/30 GALLON MULTI TANK SKID

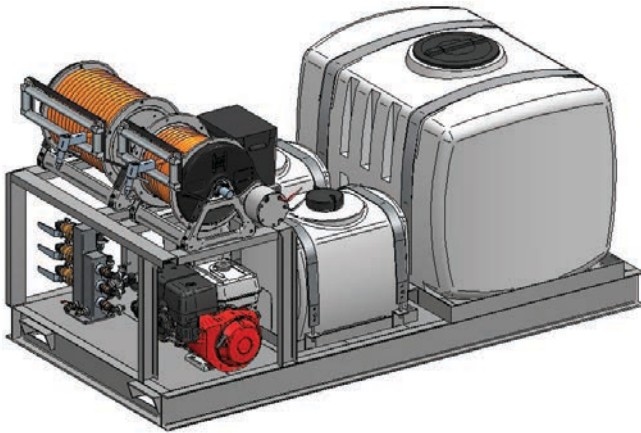

200/30/30 Gallon Poly - Skid Layout

- (1) 200 Gallon Poly PCO Tank
- (2) 30 Gallon Poly PCO Tank
- (1) 300' of 1/2" Spray Hose, w/ Quick Coupler
- (1) 300' of 3/8" Spray Hose, w/ Quick Coupler
- (2) 12V Electric Hose Reel, w/ Roller Guides
- (1) Choice of Pump
- (1) 8 HP Honda Engine, Electric Start
- (2) JD9 Trigger Spray Gun, w/ Quick Coupler

- 3/4" Tank Mounted Air Gap Fill
- Roller Guides on Hannay Hose Reel
- Adjustable High Pressure Jet Agitation
- Remote Mounted Suction Strainer-Filter
- Chemical Resistant Polyethylene Tanks 5 Year UV Rated
- Corrosion Resistant T6061 Aluminum Frame
- All Fittings Poly, Brass, or Stainless Steel
- Factory Tested w/ OEM Parts Registration
- Long Life, Fuel-Efficient Honda Engines
- Air Gap Fillers Included
- Battery, Battery Box, and Wiring

Pump Options

- Udor Kappa55 (15 GPM, 560 PSI)
- Hypro D50 (14 GPM, 580 PSI)
- Larger Pumps and Engines Available

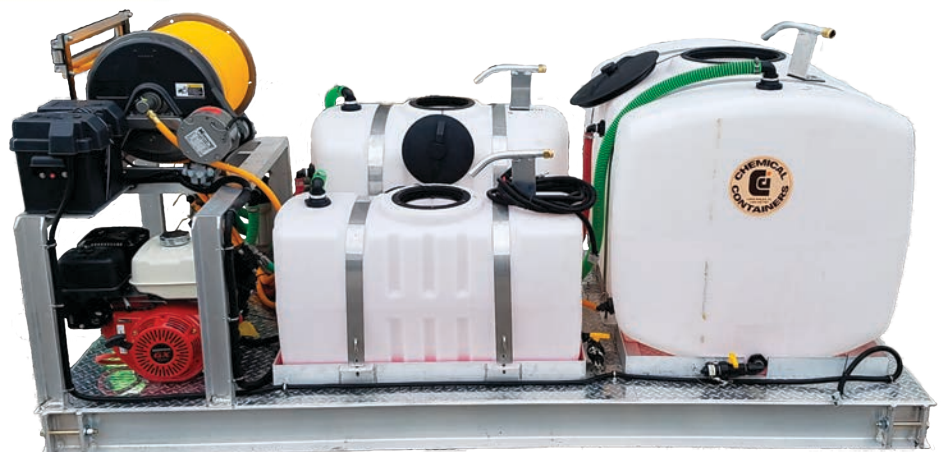
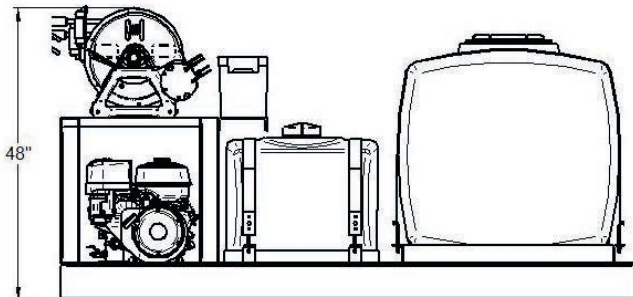
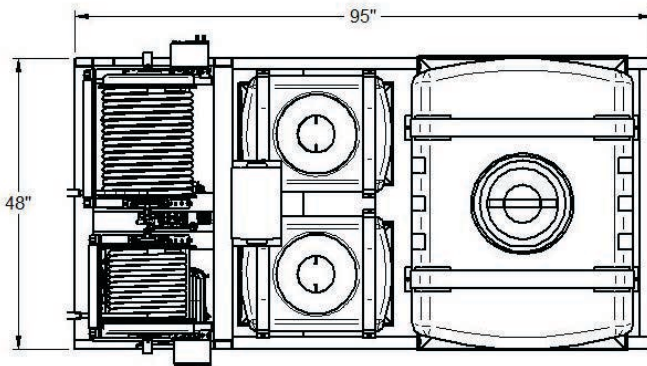



300/100/100 GALLON MULTI TANK SKID

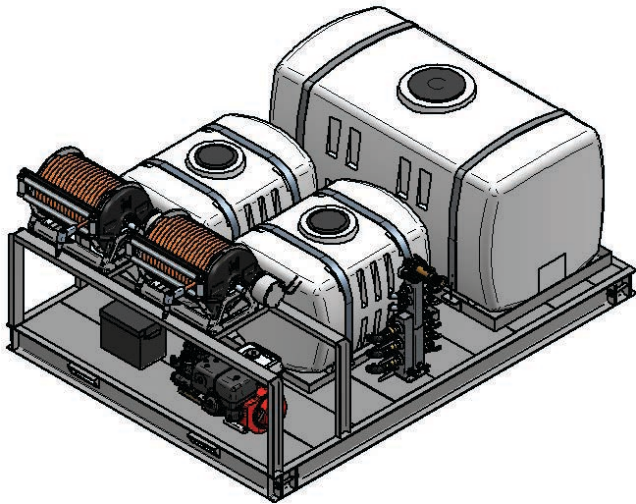

300/100/100 Gallon Poly - Skid Layout

- (1) 300 Gallon Poly PCO Tank
- (2) 100 Gallon Poly PCO Tank
- (2) 300' of 1/2" Spray Hose, w/ Quick Coupler
- (2) 12V electric Hose Reel, w/ Roller Guides
- (1) Choice of Pump
- (1) 8 HP Honda Engine, Electric Start
- (2) JD9 Trigger Spray Gun, w/ Quick Coupler

- 3/4" Tank Mounted Air Gap Fill
- Roller Guides on Hannay Hose Reel
- Adjustable High Pressure Jet Agitation
- Remote Mounted Suction Strainer-Filter
- Chemical Resistant Polyethylene Tanks 5 Year UV Rated
- Corrosion Resistant T6061 Aluminum Frame
- All Fittings Poly, Brass, or Stainless Steel
- Factory Tested w/ OEM Parts Registration
- Long Life, Fuel-Efficient Honda Engines
- Air Gap Fillers Included
- Battery, Battery Box, and Wiring

Pump Options

- Udor Kappa55 (15 GPM, 560 PSI)
- Hypro D50 (14 GPM, 580 PSI)
- Larger Pumps and Engines Available

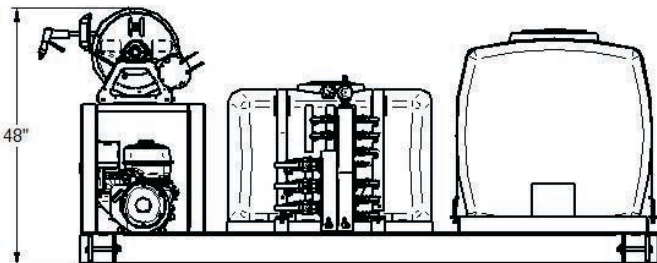
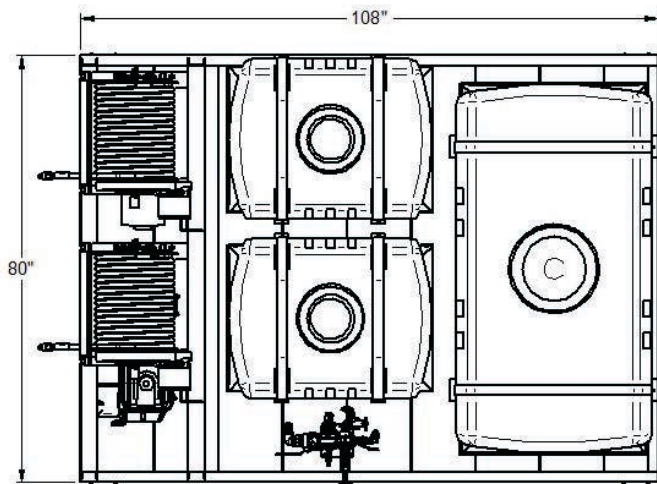



300/200/100 GALLON MULTI TANK SKID

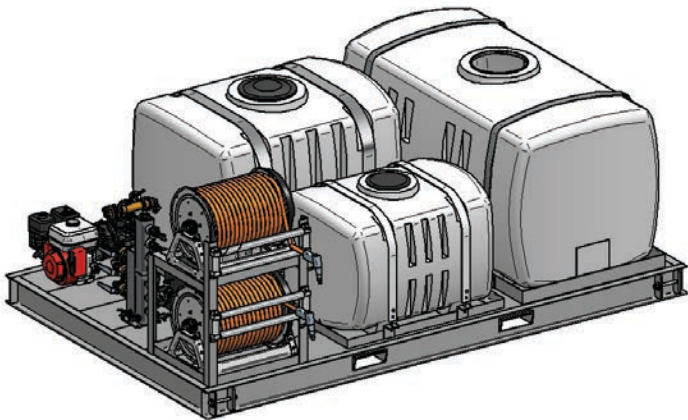

300/200/100 Gallon Poly - Skid Layout

- (1) 300 Gallon Poly PCO Tank
- (1) 200 Gallon Poly PCO Tank
- (1) 100 Gallon Poly PCO Tank
- (2) 300' of 1/2" Spray Hose, w/ Quick Coupler
- (2) 12V Electric Hose Reel, w/ Roller Guides
- (1) Choice of Pump
- (1) 8 HP Honda Engine, Electric Start
- (2) JD9 Trigger Spray Gun, w/ Quick Coupler

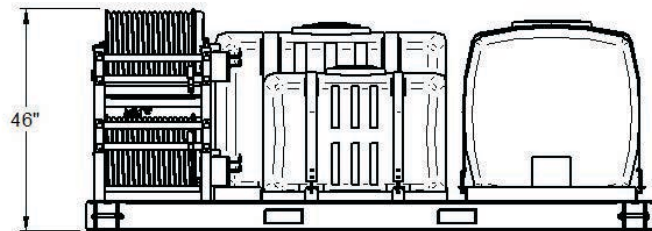
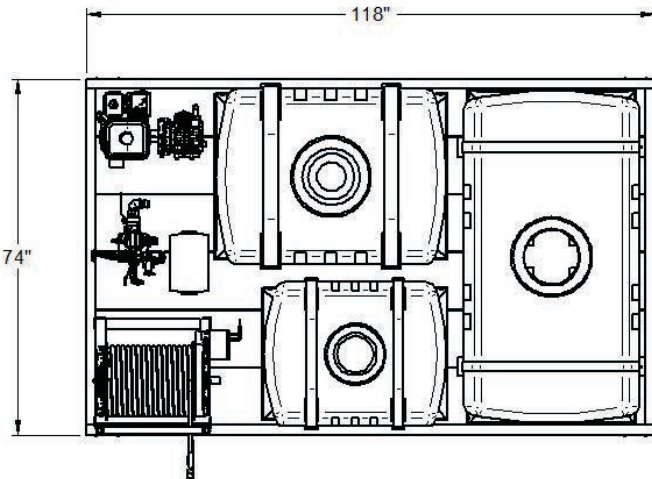

- 3/4" Tank Mounted Air Gap Fill
- Roller Guides on Hannay Hose Reel
- Adjustable High Pressure Jet Agitation
- Remote Mounted Suction Strainer-Filter
- Chemical Resistant Polyethylene Tanks 5 Year UV Rated
- Corrosion Resistant T6061 Aluminum Frame
- All Fittings Poly, Brass, or Stainless Steel
- Factory Tested w/ OEM Parts Registration
- Long Life, Fuel-Efficient Honda Engines
- Air Gap Fillers Included
- Battery, Battery Box, and Wiring

Pump Options

- Udor Kappa55 (15 GPM, 560 PSI)
- Hypro D50 (14 GPM, 580 PSI)
- Larger Pumps and Engines Available





LAWN CARE TRUCK

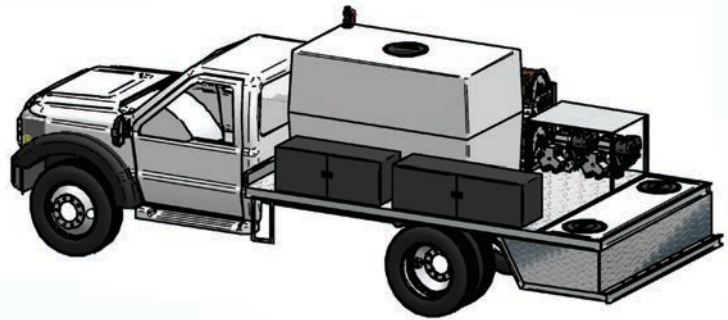
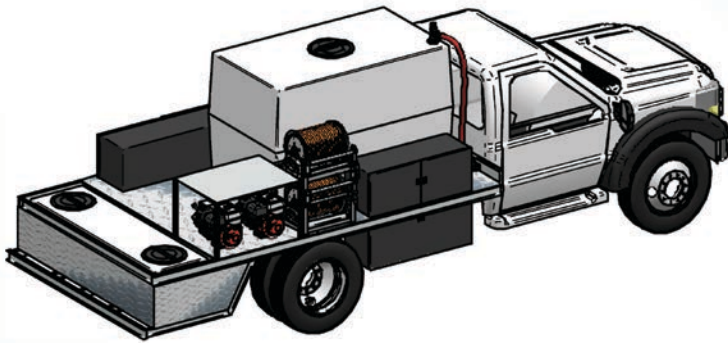

Lawn Care Truck Layout

- (1) 600 Gallon Fiberglass Tank
- (1) 200 Gallon Fiberglass Split Drop Tank (100-100)
- (2) 300' of 1/2" Spray Hose, w/ Quick Coupler
- (2) 12V Electric Hose Reel, w/ Roller Guides
- (2) Udor Kappa55 Pump (15 gpm, 560 psi)
- (2) 5.5 HP Honda Engine, Electric Start
- (2) JD9 Trigger Spray Gun, w/ Quick Coupler

- 2" Cam Lock Overhead Fill w/ Vacuum Break
- Roller Guides on Hannay Hose Reel
- Adjustable High Pressure Jet Agitation
- Remote Mounted Suction Strainer-Filter
- Corrosion Resistant T6061 Aluminum Body
- All Fittings Poly, Brass, or Stainless Steel
- Factory Tested w/ OEM Parts Registration
- Long Life, Fuel-Efficient Honda Engines
- DOT Lighting
- Battery, Battery Box, and Wiring
- Stainless Steel Tool Boxes





ENCLOSED LAWN CARE TRUCK

Enclosed Lawn Care Truck Layout

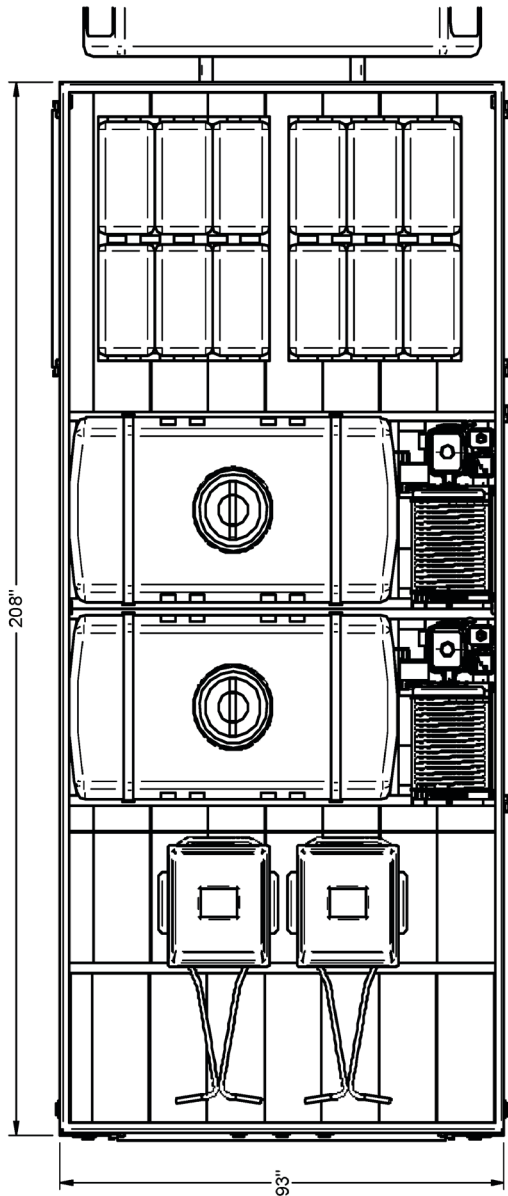

- (2) 300 Gallon Poly PCO Tank
- (2) 300' of 1/2" Spray Hose, w/ Quick Coupler
- (2) 12V Electric Hose Reel, w/ Roller Guides
- (2) Udor Kappa43 Pump (10 gpm, 560 psi)
- (2) 5.5 HP Honda Engine, Electric Start
- (2) JD9 Trigger Spray Gun, w/ Quick Coupler

- Roller Guides on Hannay Hose Reel
- Adjustable High Pressure Jet Agitation
- Remote Mounted Suction Strainer-Filter
- Chemical Resistant Polyethylene Tanks 5 Year UV Rated
- Corrosion Resistant T6061 Aluminum Frame
- All Fittings Poly, Brass, or Stainless Steel
- Factory Tested w/ OEM Parts Registration
- Long Life, Fuel-Efficient Honda Engines
- DOT Lighting
- Battery, Battery Box, and Wiring
- Custom Design Available

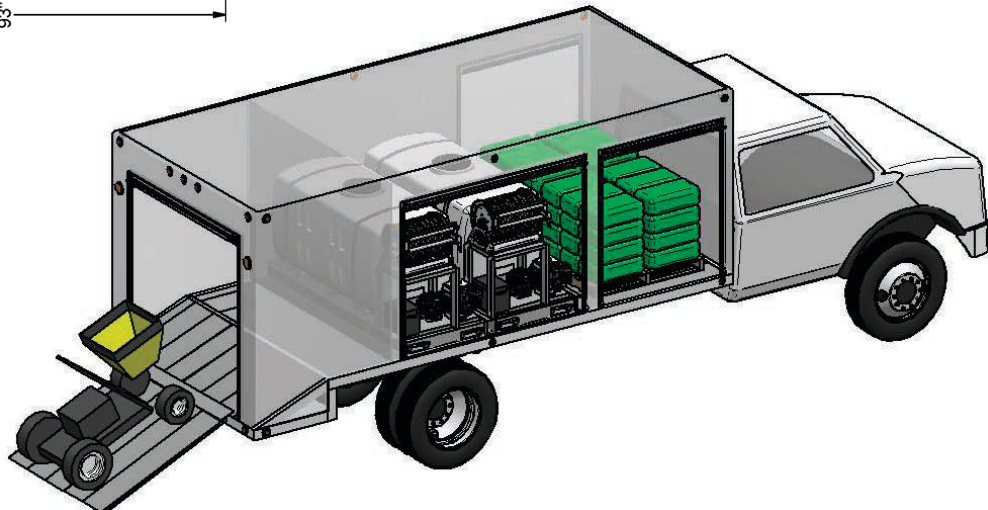
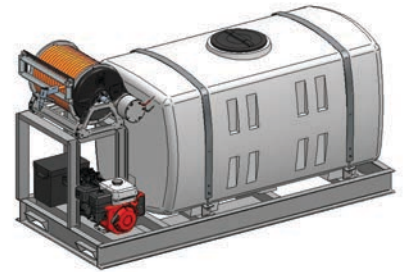

- **2 REMOVEABLE, COMPLETE SKID UNITS**





PUMPS, ENGINES, & METERS

MOST POPULAR HYPRO PUMPS

	<ul style="list-style-type: none"> • Max. flow: 6 gpm • Max. pressure: 363 psi • Max. rated speed: 650 rpm • Port sizes: 3/4" HB inlet, 1/2" NPT outlet • Shaft : 3/4" solid keyed
	<ul style="list-style-type: none"> • Max. flow: 9.5 gpm • Max. pressure: 580 psi • Max. rated speed: 550 rpm • Port sizes: 1" HB inlet, 1/2" HB outlet • Shaft: 3/4" solid thru-shaft
	<ul style="list-style-type: none"> • Max. flow: 14 gpm • Max. pressure: 580 psi • Max. rated speed: 550 rpm • Port sizes: 1-1/4" HB inlet, 1/2" HB outlet • Shaft: flange with 1" shaft ext.

OTHER HYPRO PUMPS

			
<ul style="list-style-type: none"> • D70 • 20 GPM • 290 PSI 	<ul style="list-style-type: none"> • D115 • 30 GPM • 290 PSI 	<ul style="list-style-type: none"> • D135 • 35 GPM • 290 PSI 	<ul style="list-style-type: none"> • D160 • 42 GPM • 290 PSI
			
<ul style="list-style-type: none"> • D250 • 66 GPM • 290 PSI 	<ul style="list-style-type: none"> • D403 • 10 GPM • 580 PSI 	<ul style="list-style-type: none"> • D503 • 14 GPM • 580 PSI 	<ul style="list-style-type: none"> • D1064 • 28 GPM • 725 PSI



	Pump	Engine	Volume	Pressure	Diaph. Kit	Valve Kit
1	Kappa25/GR	Honda 4.0 HP	7.0 gpm	350psi	8700.65	6006.01
2	Kappa40/GR	Honda 5.5 HP	10.5 gpm	560psi	8700.02	6006.01
3	Kappa43/GR	Honda 5.5 HP	12.5 gpm	560psi	8700.45	6006.01
4	Kappa55/GR-5	Honda 5.5 HP	15gpm	350psi	8700.26	6006.01
5	Kappa55/GR-8	Honda 8 HP	15gpm	560psi	8700.26	6006.01
6	Kappa75/GR	Honda 13 HP	20gpm	560psi	8700.10	6006.01
7	Kappa120/GR	Honda 20 HP	35gpm	700psi	8700.22	6006.08
8	Beta150	PTO - 35 HP	42gpm	700psi	8700.07	6006.08



HONDA

		
<ul style="list-style-type: none"> • GX100 	<ul style="list-style-type: none"> • GX160 • 4.8 HP 	<ul style="list-style-type: none"> • GX240 • 7.1 HP
		
<ul style="list-style-type: none"> • GX340 • 9.5 HP 	<ul style="list-style-type: none"> • GX390 • 11 HP 	<ul style="list-style-type: none"> • GX670 • 20.5 HP

ELECTRIC PUMPS & REBUILD KITS

Flo-Jet

- CCI Part # P1499
- 12V DC
 - Max: 45 PSI
 - Max: 3.7 GPM
 - Ports: 1/2" Barb



Flo-Jet

- CCI Part # P1500
- 12V DC
 - Max: 60 PSI
 - Max: 2.2 GPM
 - Ports: 3/8" FPT



Flo-Jet

- CCI Part # P1501
- 115V AC
 - Max: 60 PSI
 - Max: 1.6 GPM
 - Ports: 3/8" FPT



Flo-Jet

- CCI Part # P1511
- 12V DC
 - Max: 70 PSI
 - Max: 1.8 GPM
 - Ports: 3/8" FPT



Shur-Flo

- CCI Part # P1599
- 12V DC
 - Max: 60 PSI
 - Max: 1.0 GPM
 - Ports: 3/8" FPT



Shur-Flo

- CCI Part # P1600
- 12V DC
 - Max: 60 PSI
 - Max: 1.4 GPM
 - Ports: 3/8" FPT



Shur-Flo

- CCI Part # P1601
- 12V DC
 - Max: 45 PSI
 - Max: 3.0 GPM
 - Ports: 1/2" MPT



CHEM-PUMPS & METERS

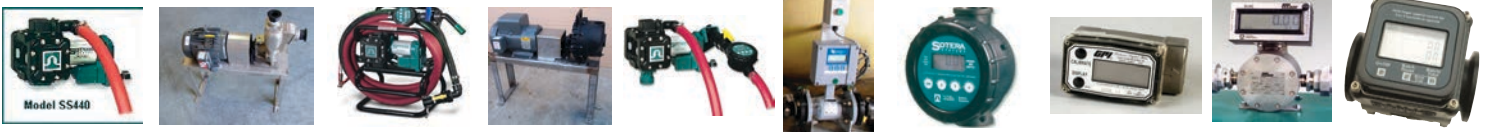



TANKS

VERTICAL TANKS



- Available from 10 gallons up to 20,000 gallons
- Available in premium, heavy duty and water only models

CONE BOTTOM TANKS



- Available from 55 gallons up to 10,000 gallons
- Available with poly or metal stands
- Available in open top and closed top models

APPLICATOR TANKS



- Available from 20 gallons up to 500 gallons
- Can be purchased with or without tank saddles

DOUBLE WALL TANKS



- Available from 30 gallons up to 8,700 gallons
- Double walls for extra strength, durability, and containment

ELLIPTICAL TANKS



- Available from 200 gallons up to 1,600 gallons
- Can be purchased with or without tank skid

PCO TANKS



- Available from 30 gallons up to 300 gallons
- Ribbed design for extra strength

HORIZONTAL LEG TANKS



- Available from 35 gallons up to 5,025 gallons
- Many different dimensional options
- Fitted tank bands available for every size

ELLIPTICAL LEG TANKS



- Available from 335 gallons up to 4,035 gallons
- Low center of gravity for stability during travel
- Fitted tank bands available for every size

FIBERGLASS TANKS



- Available from 35 gallons up to 20,000 gallons
- Premium grade resins and white gel-coat finish
- Available in standard, drop tank and split models





COMPLETE UNITS AND KITS

SPOT SPRAYERS



- Conventional spot sprayers available from 15 to 60 gallons (larger sprayers available with PCO, loaf and leg tanks)
- Many pumps available to achieve desired output
- Available with brackets, frames and skids (we can customize to meet your needs)

BACKPACK SPRAYERS



2 Gallon Super Sprayer

Model: FSPS0010A

- Funnel Fill Opening
- 48" Braided Hose
- 18" Poly Wand
- Flat and Cone Nozzles Included

4 Gallon SP1 Bak-Pak Sprayer

Model: FSPS003

- 20" Brass Wand
- Viton® Seals
- Includes 3 Flat Fan Nozzles

Diaphragm Kit Model: FSPS4KIT

4 Gallon Commercial Bak-Pak Sprayer

Model: FSPS001

- Extra Large Fill Opening
- 48" PVC Hose
- 20" Poly Wand
- Bonus 4 Setting Nozzle

4 Gallon Effortless Backpack Sprayer

- No Hand Pumping
- Powered by a commercial grade 20-volt Lithium Ion battery.
- Sprays up to 23 tanks on a single charge.
- Pump delivers a constant 40 PSI.

SPILL & DECONTAMINATION KITS



Decontamination Tank

- 4 gallon poly tank w/ 2 compartments
- 1 compartment for liquid, 1 for safety equipment
- Also comes as a kit w/ safety equipment included

Hand Wash Kits

- 6 & 12 gallon kits available
- Comes w/ fittings and lid



EMERGENCY EYE WASH & SHOWER



PARTS

**YOU WANT IT, WE GOT IT! OVER 15,000 PARTS IN STOCK, READY FOR DELIVERY, READY FOR PICK UP!
FULL PARTS STAFF READY TO ASSIST YOU. SAME DAY DELIVERY AVAILABLE.
MOBILE SALES PEOPLE FOR ON-SITE SERVICE.**

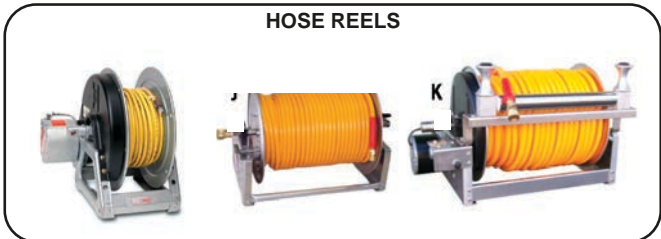
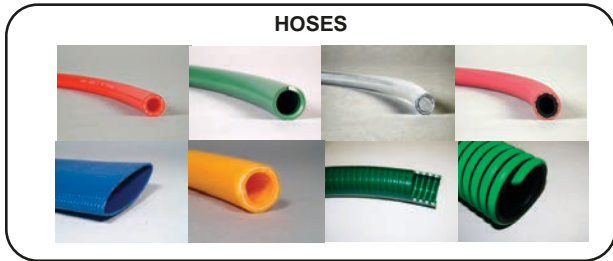
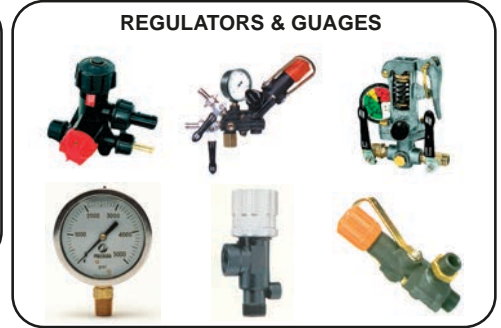
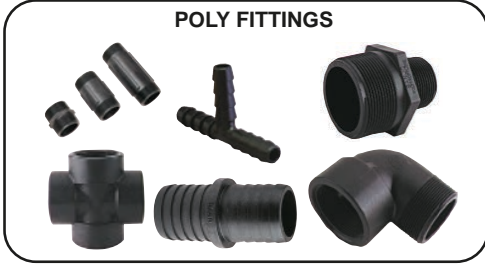



a distributor of...



THE BEST GRANULAR MATERIAL APPLICATION METHOD ON THE MARKET!



- UP TO 60% REDUCTION IN MATERIAL USED
- REDUCED LABOR
- ELIMINATES HOT SPOTS WITH EVEN PRECISION COVERAGE
- FULLY ADJUSTABLE RATES - SELECTED CONTINUOUS FEED OR ELECTRONICALLY MONITORED AMOUNTS
- THROWS UP TO 30'
- APPLIES DRY FERTILIZER, GRANULAR PRE-EMERGENT, ICE MELT, AQUATIC HERBICIDES, DEER & TICK REPELLANT, ETC.

TR MODEL
250 LB CAPACITY



SPC MODEL
70 LB CAPACITY





ATV BOOMS AND SPRAY SYSTEM PARTS

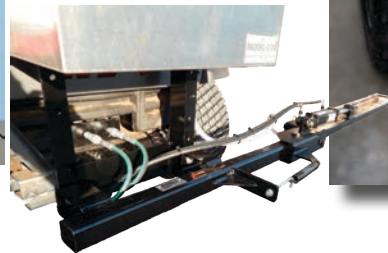

SPRAY SYSTEM PARTS

AITTJ60 High Capacity Air Induction Turbo Twin-Jet Tips



AI3070 Air Induction Dual Pattern Flat Spray Tips



XR Extended Range Flat Spray Tips



TXR ConeJet Hollow Cone Spray Tips



QJ380 & QJ380F High-Capacity Nozzle Bodies



QJS Stackable Nozzle Body



Quick TeeJet

WET BOOMS



QJ360E NOZZLE BODY FOR WET BOOMS

- Available to fit 20 mm O.D tubing only
- Flow rate: 1.5 GPM at 5 PSI pressure drop, 2.1 GPM with 10 PSI pressure drop.
- Reduced internal cavity to increase ChemSaver shut-off speed
- Notched inlet tube allows for more complete boom drainage and reduces sediment buildup.

Quick TeeJet

DRY BOOMS

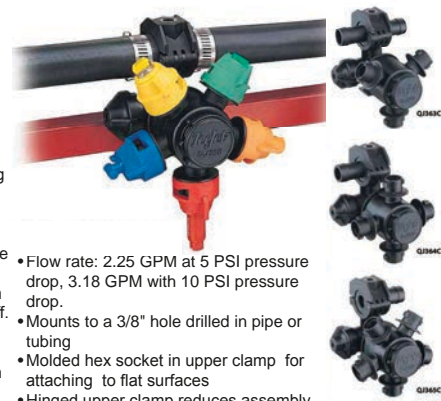

QJ360C NOZZLE BODY FOR DRY BOOMS

- Available with either 3, 4 or 5 spray positions for easy change of spray tips or quick boom flushing
- Positive shutoff between each spray
- Automatic spray alignment using flat fan spray tips.
- Maximum operating pressure of 300 PSI
- Available in 1/2", 3/4" or 1" single or double hose shanks.
- Includes ChemSaver diaphragm check valves for drip-free shutoff. Standard diaphragm opens at 10 PSI.
- Standard EPDM diaphragm with Viton available as an option
- Durable design mounts body high on boom structure for maximum protection

- Flow rate: 2.25 GPM at 5 PSI pressure drop, 3.18 GPM with 10 PSI pressure drop.
- Mounts to a 3/8" hole drilled in pipe or tubing
- Molded hex socket in upper clamp for attaching to flat surfaces
- Hinged upper clamp reduces assembly time and fits inside common boom channels

TeeJet VisiFlo® Flat Spray Tips

- FEATURES:**
- Tapered edge flat spray pattern for uniform coverage in broadcast spraying
 - VisiFlow color-coded version available in stainless steel, ceramic and polymer in 80° or 110° spray angles in selected sizes
 - Available in ceramic 80° capacities 01-02 and 110° capacities 01-015
 - Standard version (not color-coded) available in 15°, 25°, 40°, 50° and 65° spray angles in brass, stainless steel and hardened stainless steel.
 - Automatic spray alignment with 25612-⁺NYR Quick TeeJet cap and gasket



FEATURES:

- Excellent spray distribution over a wide range of pressures 50-60 PSI.
- Ideal for rigs with sprayer controllers.
- Reduces drift at lower pressures, better coverage at lower pressures.
- Available in stainless steel, ceramic and polymer in 80° and 110° spray angles with VisiFlo color-coding.



XR TeeJet Extended Range Flat Spray Tips

TurfJet Wide Angle Flat Fan Spray Nozzles

FEATURES:

- Can be used with Quick TeeJet cap QJ4676-⁺NYR.
- Very large droplets.
- Direct replacement for placis hollow-cone, low-drift nozzles.
- More precise flow and distribution pattern. Large orifice reduces clogging.
- Nozzle spacing 20-40"
- Spraying pressure 25-75 PSI





CUSTOM EQUIPMENT



CCI Commercial Spray Rigs:

- Open or all enclosed body styles
- All welded unitized aluminum structure with aircraft grade aluminum bodies
- PTO or Honda driven pumps for tree and/or lawn spraying applications
- Structural decking for maximum load capacity
- Curbside operator controls
- DOT - LED lighting and safety strobe lights
- Dover aluminum locking roll-up doors
- Custom interior shelving and dividers
- High pressure jet agitation available
- Stainless steel control manifolds
- Epoxy primer coat with chemical resistant, industrial grade, polyurethane enamel finish
- Complete user's manual and full 1 year warranty



VISIT OR CALL ANY OF OUR CONVENIENT LOCATIONS!

CCI Clewiston

742 E Sagamore
Clewiston, FL 33440
(863) 301-3520

CCI Lyons

699 South State Street
Lyons, GA 30436
(912) 388-2154

CCI Lake Wales

413 ABC road
Lake Wales, FL 33898
(863) 638-1407

CCI Sebring

6402 US Hwy 27 South
Sebring, FL 33876
(863) 314-6647

CCI Zolfo Spring

3322 Hwy 17 S.
Zolfo Springs, FL 33890
(863) 474-3051

CCI Arcadia

440 N Brevard Avenue
Arcadia, FL 34266
(863) 491-0165

CCI Ft. Pierce

15897 Orange Avenue
Ft. Pierce, FL 34945
(772) 801-5326

CCI Plant City

601 Hitchcock Street, Suite 103
Plant City, FL 33563
(813) 752-1982

SPECIALISTS IN LIQUID ***HANDLING PRODUCTS***

EST. 1983